

Drawing ID

C-180FX

Product Info.

Finish	Code
Polish	C-180FM
Satin	C-180FS
Texture Black	C-180FB
White	C-180FW
Brush Brass	C-180FBB

Dimensions

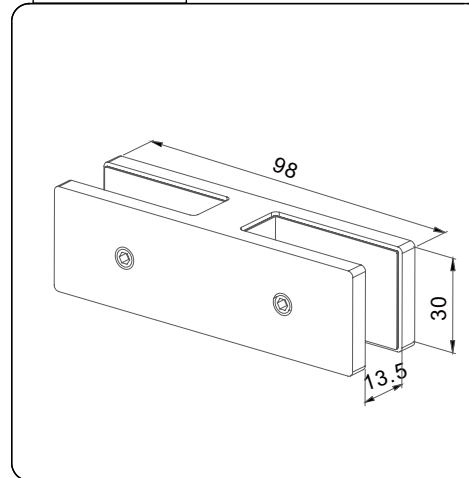

Dimensions

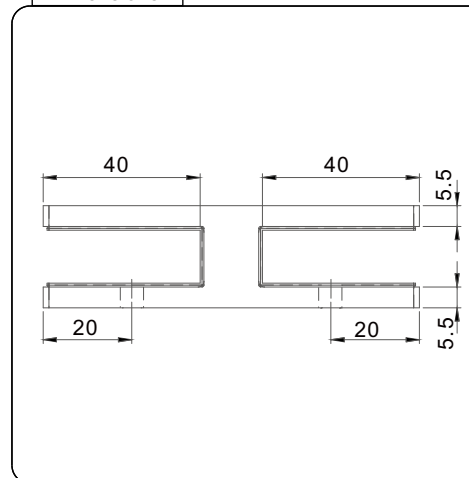

Top View

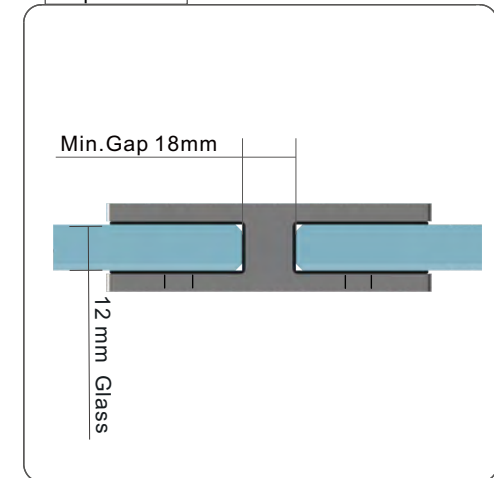

MATERIAL:

Duplex 2250 Stainless Steel

CATALOGUE AND DESCRIPTION:

- > Glass Fixing System
- > Glass Clamp
- > Friction Fit Glass to Glass 180° Clamp

NOTES:

This drawing and or specification is the property of Silver Stone Hardware Pty Ltd - and must be returned to them on request. Unauthorised use may result in Legal Action. Its contents must not be made public, nor copied, nor used directly or indirectly in any way.

SILVER STONE HARDWARE PTYLID

56-62 Bryant Street, Padstow, NSW 2211
 T: (02) 9792 2955 M: 0452 526 680
www.silverstonehardware.com.au
sales@silverstonehardware.com.au